



Development in Advancement of a Green Appoint Mechanism for Vitality Investment Funds in Cloud Gauge

¹Pooja Yadav, ²Praveen Yadav

^{1,2}Guest Assistant Professor, Department of Computer Science and Engineering, Indira Gandhi
University, Meerpur, Rewari, Haryana, India

Abstract: In terms of validating deficiencies along change in terms of financially driving our stresses present, the use of server utilization became a major problem. Unmistakably, an impressive diminishment in imperativeness usage can do by closing the servers when they are not utilized. In this concept of arranging, realizing along surveying a Green Booking Calculation organizing a neural framework pointer for streamlining server control use in Cloud figuring. We use the marker to predict future load ask for in perspective of the bona fide ask. According to the gauge, the figuring murders and not used servers and bring back them to restrain the quantity of running servers, thusly restricting the essentialness use at the motivations behind usage to benefit each and every other level.

Keywords- Power savings; scheduling; estimation; data enters

I. INTRODUCTION

Distributed computing [1] has risen as another plan of action of calculation and capacity assets in view of on-request access to possibly noteworthy measures in virtual data centre abilities. As the area of develops by constant development in terms of internet and the world's organizations, it's normal more than Cloud suppliers that show up that gives a assorted choice of various assets along administrations. In any case, the sending of server farms in Clouds has put an ever increasing number [2] of PCs being used every year, expanding vitality utilization and negative weight on the earth. Despite the fact that this approach can give a critical lessening in control utilization, it relies upon the equipment segments' settings to perform scaling undertakings. Then again, the last guarantees most power reserve funds, as it guarantees almost zero power devoured by being-killed servers. In any case, past works which adopted this strategy experienced issues to guarantee [3] benefit level understanding because of the absence of a solid apparatus for anticipating future request to help the killing/on basic leadership. Here, we mean to configuration, actualize along assess



a Green Scheduling Mechanism incorporating a neural system indicator in upgrading servers control utilization in Cloud processing situations by closing unused servers[4]. These system indicator which we had grown before has been demonstrated to have a profoundly precise forecast capacity in order to fix in powerful constant changes [5]. Utilization of the indicator is to help out the calculation keenly makes suitable killing choices, along to make mechanism more pragmatic. As VM's are produced on request to address the client's issues in Clouds, the indicator is utilized for anticipate eventual request on server in view of chronicled request. Our planning calculation fills in as takes after [6]. As indicated by the forecast, the calculation first gauges need dynamic task load on the servers.

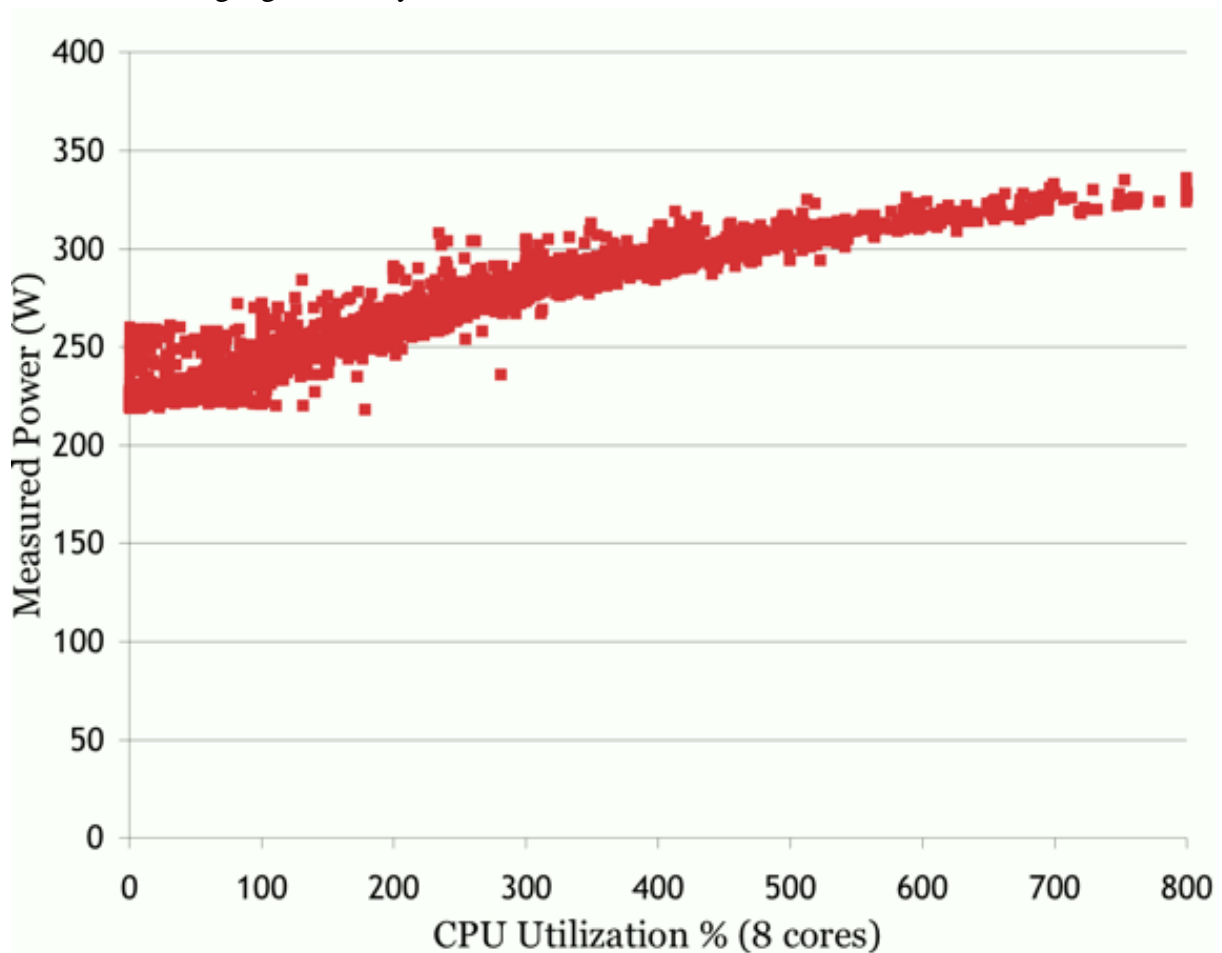

Figure1: CPU Usage along power Utilization

The remaining part is sorted out as takes after [7]. Area 2 presents foundation data and related work. The power utilization of servers is inspected in Section 3. Segment 4 shows the framework demonstrates, the neural indicator, along calculation. Segment 5 dissects test system depictions and reproduction comes about. At long last, we finish up our examination in Section 6.



II. Literature Survey

Numerous concepts have considered dynamic recurrence measuring strategy in overseeing vitality along service provider assets in groups as well as information/facilitating focuses. The task [8] has predominantly centered around solitary service provider configuration and the vitality utilization was diminished versatile calculations for recurrence changes. In [9], a group position mechanism was proposed [10], despite fact that the genuine power diminishment is picked up at certain processor maintenance position additionally by altering the recurrence. An escalated work was acquainted in with locate the particular connection amongst power and recurrence for ideal power assignment at position of server ranches. Despite the fact that recurrence scaling strategy offers considerable power investment funds, it depends on the changes of equipment parts to do changes undertakings. A current pattern is to characterize uncommon conditions [11] of servers which can give vitality funds while having the capacity to play out some pre-characterized errands. In [9], PowerNap was proposed as a way to deal with vitality preservation, where the service provider moves quickly among a dynamic state along an almost zero-control sit still state, known as "rest" position, in light of load. Another exceptional condition of the server, called "Somniloquy", was exhibited in [12] to expand arrange interfaces along empower a server to react to organize activity.

III. Getting know about Power Consumption

To get more precise information, the CPU use is kept up at steady position for some time. Later normal recorded energy utilization of the period is accounted for. Energy utilization has all the earmarks of being relatively direct with processor usage. An expansion of 21% in CPU usage prompts an increment of roughly 7.5% and 4% in control utilization in the 1/4th –centre [13]. Also, we watch the sit out of gear state expends a considerable measure of vitality, as much as 62%, if there should be an occurrence of the quad-centre machine, and 78% on account of the double centre machine, of the pinnacle control [14]. This perception infers that there is space for control protection and consequently, an extensive power lessening can be accomplished by transferring sitting servers to less control position.

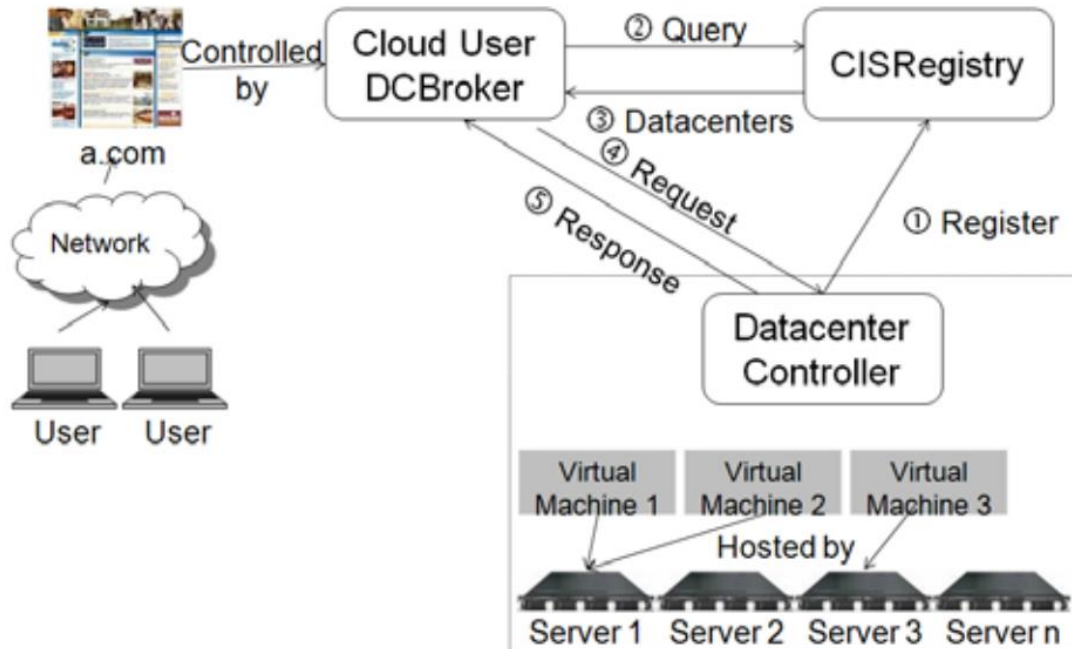

Figure2: The System Model

Regarding power utilization as well as progress late, it require just 10 sec to result in these present circumstances position from sit position, along 20 seconds from the other way. The pinnacle control brought about amid the change is equal to approximately 30% CPU use [15]. So also, the standby state is a decent contender to swap the sit out of gear state for sparing vitality in Windows.

IV. Architectural Model, Algorithm Designing

A. The System Model Figure 2 portrays framework display of this concept... As a matter of fact, it speaks to a straightforward design of Cloud figuring, where a Cloud supplier, comprising of an accumulation of Data-centres and CAS registry gives utility processing administration to Cloud clients. The Cloud clients, thusly, utilize the utility figuring administration to wind up a Seas supplier and give web apps to the clients. An ask for from a Cloud client is handled in a few stages as takes after [16].

- ① Data enters enrol their data with the Registry.
- ② Cloud client questions the CAS registry for server farms' data.
- ③ The CAS registry reacts by sending a rundown of accessible data enters to the client.
- ④ the client demands handling components by vm's.
- ⑤ the rundown of accessible VM's is sent back for serving demands from clients to administrations facilitated by client [17].

What's more, it has a few controllers which have four primary capacities: (1) enlisting the data centre's data, (2) tolerating demands from Cloud clients, (3) disseminating load (4) running the green booking calculation for settling on choice on demolition of VM's in servers.

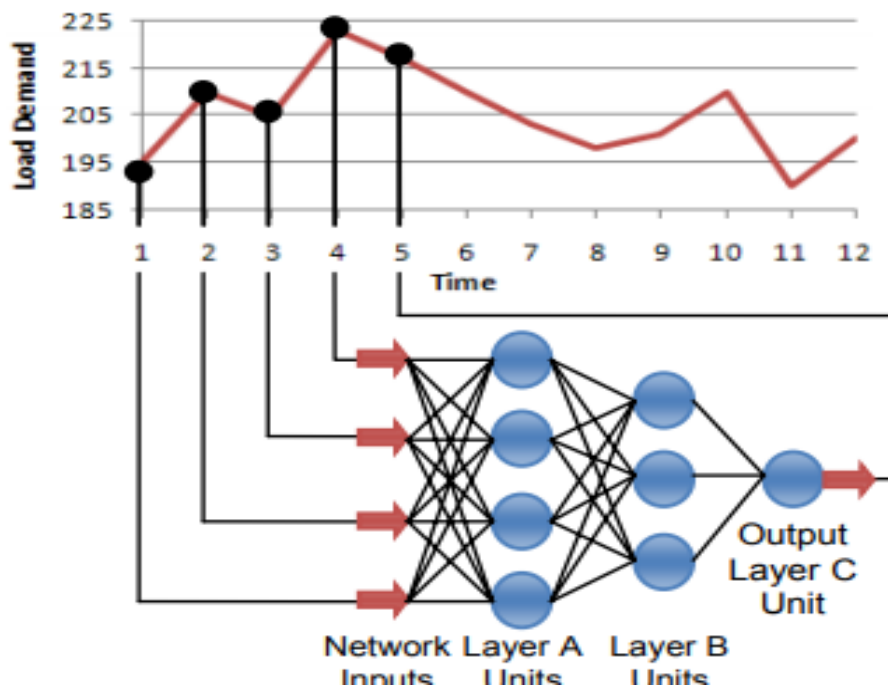

Figure 3:3 layer network Predictor

B. The Neural Predictor [18]

It is perfumed with a period game plan input is given in Figure 5. The framework having 4 compose tasks where extra task is gotten and 1 yield layer C with 1 unit where the game plan is gained. The framework data along yield layers are confined by 2 hid layers: layer A with 4 units and layer B with 3 units.

$$O_c = h\left(\sum_{i=1}^n x_{c,i} w_{c,i} + b_c\right)$$

$$\text{where } h(x) = \begin{cases} \frac{1}{1+e^{-x}} & \text{if hidden layer node} \\ x & \text{if output layer node} \end{cases}$$

Where

Co is result of present node,



N is number of nodes in before layer,
Chi is an input to the present node from the before layer,
Chi is weight modifying the corresponding connection from chi, and
By is bias.

Algorithm:

Inputs: list of servers in the datacenter and their current state; $T_{RESTARTING}$: delay necessary for a server to come to ON from OFF; C : server capacity.

Output: decision for ON/OFF and updated list of servers.

Periodically do at each time unit t (Evaluation phase)

Ask the predictor to predict loads from time t to time $t + T_{RESTARTING}$ based on the collected historical loads during the period of $[0, t - 1]$

Find the peak load L_p from time t to time $t + T_{RESTARTING}$

Find the number of necessary servers at time t : $N_t = \lceil L_p \div C \rceil$

Assume $N_c =$ number of servers in ON state

If $N_t = N_c$: no action

Else if $N_t > N_c$: choose $(N_t - N_c)$ servers in OFF state and signal them to restart

Else if $N_t < N_c$: choose $(N_c - N_t)$ servers in ON state with free processing cores and signal them to shutdown.

C. The Green Scheduling Algorithm

The green planning calculation, portrayed in Figure 6, is a key part of figuring out which servers ought to be killed/on. It will turn on servers [19] when the heap increments and the other way around, kill servers when the heap diminishes. Nonetheless, as it sets aside some time for a server to come to the full task, it must be turned on before it is really required.

V. EXPERIMENTAL RESULTS

The re-enactment of ESF-ES green undertaking booking calculation for a server farm with heterogeneous assignments is finished utilizing java thus that the server vitality utilization can be decreased to a specific degree[20]. The purpose behind calling as green assignment booking calculation is that when the vitality utilization is diminished, the carbon dioxide gas emanation can likewise be lessened bringing about the improvement of green



figuring innovation. A vitality effective undertaking booking calculation specifically ESF-ES is executed in this paper. Info is the quantity of servers which handles heterogeneous assignments. The quantity of servers is taken as 5. Four diverse errand writes are considered specifically perusing document substance, refreshing information, transferring records and downloading programming. The calculation is actualized in Java. The preparing time (ms) taken for each errand differs relying on their undertaking writes. For each re-enactment, the handling time (pt) and the quantity of directions for each errand (R) are arbitrarily produced. The preparing time for the errand write perusing record substance runs between $1000 \leq pt \leq 1200$; for refreshing information, $1300 \leq pt \leq 1500$; for transferring documents, $1600 \leq pt \leq 1900$; for downloading programming, $2000 \leq pt \leq 2500$. The quantity of guideline for each assignment changes $1000 \leq R \leq 9000$, $1000 \leq 1500$ and $3 \leq 4$. The correlation is made between three calculations in particular cross breed calculation, most-productive server first plan and ESF-ES calculation. The vitality utilization of server farm servers is estimated in joules (J) and the handling time is estimated in mille seconds I C I, j (ms). The handling time is utilized for computing the vitality incline which thus utilized as a part of the figuring for vitality utilization.

VI. CONCLUSION AND FUTURE WORK

This paper has displayed a Green Booking Computation that makes usage of neural framework pointer in essentialness subsidizes at Conveyed processing. The marker is abused to expect extended load ask for in perspective of accumulated evident demand. The computation uses the figure in affecting swinging to off situation to restrain the amount of working servers. To show the computation, we emulated generations with different parameters and with different running modes by results, we completed the best plan is the figure notwithstanding 31% additional servers for ensuring organization level.

References

- [1] "Research of cloud computing task scheduling algorithm based on improved genetic algorithm", in: *idée*.
- [2] "A Study on Scheduling Methods in Cloud Computing", *IJETTCS* Volume 2, Issue 4, Sep – Oct.
- [3] "Performance evaluation of a green scheduling algorithm for energy savings in cloud computing", *IEEE*.
- [4] "A Taxonomy and Survey of Energy-Efficient Data Centres and Cloud Computing Systems".



- [5] "A Study on Task Scheduling Algorithms in Cloud Computing", IJEIT Vole 2, Issue 11.
- [6] "Task Scheduling and Server Provisioning for Energy-Efficient Cloud-Computing Data Centres," IEEE.
- [7] "Energy-efficient task scheduling algorithms on heterogeneous computers with continuous and discrete speeds.
- [8] "Green task scheduling algorithms with energy reduction on heterogeneous computers", in PIC-2010, pp. 560–563.
- [9] "Green task scheduling algorithms with speeds optimization on heterogeneous cloud servers", ACM
- [10] "Green task scheduling algorithms with energy reduction on heterogeneous computers", in PIC-2010, pp. 560–563.
- [11] "Performance analysis of power-aware task scheduling algorithms on multiprocessor computers with dynamic voltage and speed", IEEE.
- [12] "Genetic algorithms for task scheduling problem, Journal of Parallel and Distributed Computing", Vole 70, Is 1, Pg 13–22
- [13] "Some observations on optimal frequency selection in DVFS-based energy consumption minimization", parallel and distributed systems 71 (8) 1154–1164.
- [14] "Linear combinations of DVFS-enabled processor frequencies to modify the energy-aware scheduling algorithms", in: Proc.10th IEEE, pp. 388–397.
- [15] "Scheduling with dynamic voltage/speed adjustment using slack reclamation in multiprocessor real-time systems", IEEE.
- [16] "Energy-aware parallel task scheduling in a cluster", Future Generation Computer Systems.
- [17] "On effective slack reclamation in task scheduling for energy reduction", Journal of Information Processing Systems.
- [18] "Power optimization of real-time embedded systems on variable speed processors", in: IEEE.
- [19] "Energy-efficient deadline scheduling for heterogeneous systems", Journal of Parallel and Distributed Computing.